

GNQ3L0C04

100Gb/s QSFP28 CWDM4 Optical Transceiver

Features

- Four-channel full-duplex transceiver modules
- Transmission data rate up to 26Gbit/s per channel
- Up to 2km transmission of single mode fiber
- Low power consumption <3.5W
- Operating case temperature 0°C to +70°C
- 3.3V power supply voltage
- RoHS 6 compliant
- Hot Pluggable QSFP form factor
- LC connector receptacle
- Built-in digital diagnostic function



Applications

- 100G Ethernet
- Proprietary High Speed Interconnections
- Data center
- 100G CWDM4 application with FEC

General Description

The Gearlink GNQ3L0C04 is a Four-Channel, Plug-gable, dual LC, Fiber-Optic QSFP28 Transceiver for 100G Ethernet applications. The QSFP28 full-duplex optical module offers 4 independent transmit and receive channels, each capable of 26Gbps operation for an aggregate data rate of 104Gbps 2km using single mode fiber. These modules are designed to operate over single mode fiber systems using 1271nm-1331nm DFB laser array. QSFP28 CWDM4 is one kind of transceiver which provides increased port density and total system cost savings. They are compliant with the QSFP28 MSA, CWDM4 MSA and portions of IEEE P802.3bm.

Absolute Maximum Ratings

Parameter	Symbol	Conditions	Min.	Max.	Unit
Storage Temperature	Ts		-40	+85	°C
Relative Humidity	RH		0	+85	%

Recommended Operating Conditions (T=25°C, unless noted)

Parameter	Symbol	Conditions	Min.	Typ.	Max.	Unit
Operating Case Temperature	TC		0		70	°C
Power Supply Voltage	VCC		3.15	3.3	3.45	V
Signaling Rate each Channel	DR			25.78125		Gbps
Supply Noise Rejection			---	---	100	mV
Receiver Differential Data Output			---	100		Ohm
Operating Distance	D		---	---	2	km

Electrical Characteristics(T=25°C, unless noted)

Parameter	Symbol	Conditions	Min.	Typ.	Max.	Unit
Power Consumption					3.5	W
Supply Current	Icc				900	mA

Transmitter Characteristics (T=25°C, unless noted)

Parameter	Symbol	Conditions	Min.	Typ.	Max.	Unit
Center Wavelength	λ_0		1264.5	1271	1277.5	nm
	λ_1		1284.5	1291	1297.5	nm
	λ_2		1304.5	1311	1317.5	nm
	λ_3		1324.5	1331	1337.5	nm
Side-mode suppression ratio	SMSR		30			dB
Total average launch power	Pout				8.5	dBm
Average launch power, each lane	Pf		-6.5		2.5	dBm
Optical Modulation Amplitude (OMA), each lane	TxOMA		-4		2.5	dBm
Difference in launch power between any two lanes (OMA)	Ptx,diff				4.0	dB
Transmitter and Dispersion Penalty	TDP				3	dB
Launch power in OMA minus TDP, each lane	Tx-TDP		-5			dBm
Average launch power of OFF transmitter, each lane					-30	dBm
Extinction ratio	ER		3.5			dB
Optical return loss tolerance					20	dB
Transmitter reflectance					-20	dB

Receiver Characteristics (T=25°C, unless noted)

Parameter	Symbol	Conditions	Min.	Typ.	Max.	Unit
Damage threshold	THd		3.5			dBm
Average power at receiver input, each lane			-13		2.5	dBm
Receive power, each lane (OMA)					2.5	dBm
Difference in receive power between any two lanes (OMA)					7.5	dB
Receiver reflectance					-26	dB
Receiver sensitivity (OMA)	SOMA				-11.5	dBm
LOS Assert	LOSA			TBD		dBm
LOS De-Assert	LOSD			TBD		dBm
LOS Hysteresis				TBD	6	dB

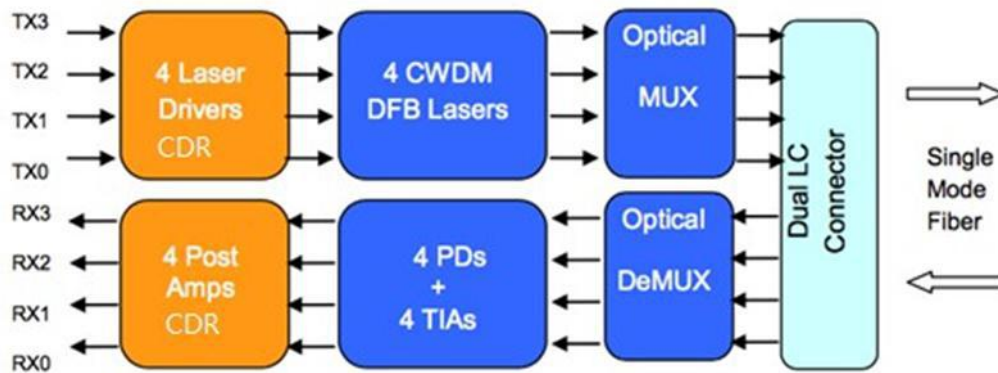
Block Diagram of Transceiver

Recommended Power Supply Filter

The host board should use the power supply filtering shown as below.

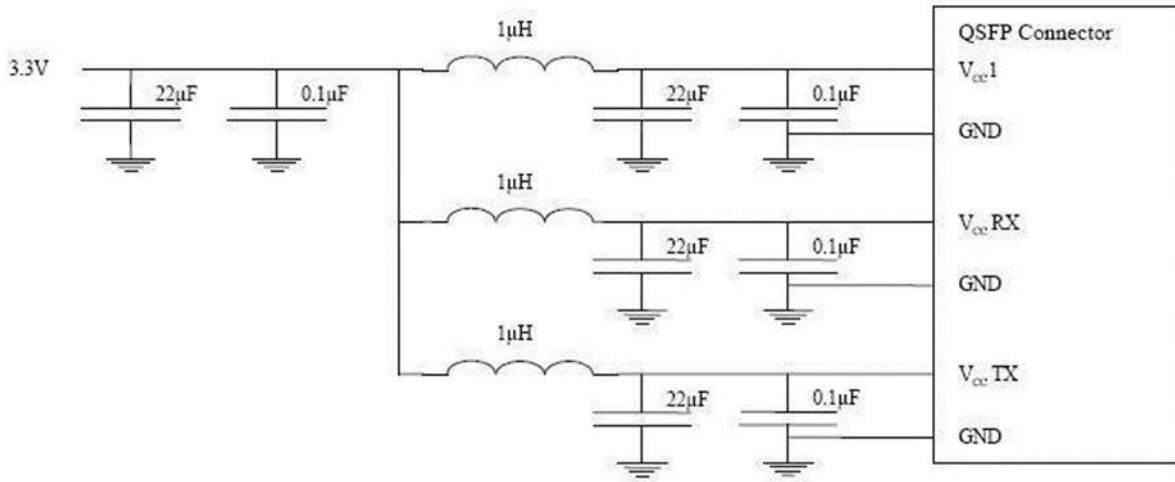

Host Board Power Supply Filtering

Pin Assignment

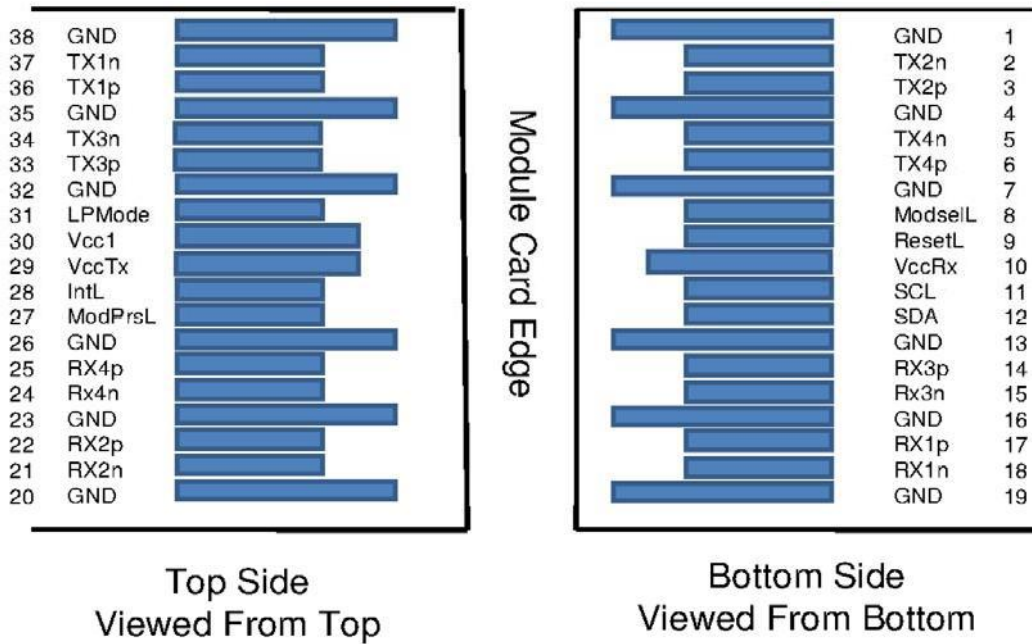

Pin Description

PIN	Logic	Symbol	Name/Description	Note
1		GND	Ground	1
2	CML-I	Tx2n	Transmitter Inverted Data Input	
3	CML-I	Tx2p	Transmitter Non-Inverted Data output	
4		GND	Ground	1
5	CML-I	Tx4n	Transmitter Inverted Data Input	
6	CML-I	Tx4p	Transmitter Non-Inverted Data output	
7		GND	Ground	1
8	LVTTL-I	ModSelL	Module Select	
9	LVTTL-I	ResetL	Module Reset	
10		VccRx	+ 3.3V Power Supply Receiver	2
11	LVC MOS-I/O	SCL	2-Wire Serial Interface Clock	
12	LVC MOS-I/O	SDA	2-Wire Serial Interface Data	
13		GND	Ground	
14	CML-O	Rx3p	Receiver Non-Inverted Data Output	
15	CML-O	Rx3n	Receiver Inverted Data Output	
16		GND	Ground	1
17	CML-O	Rx1p	Receiver Non-Inverted Data Output	
18	CML-O	Rx1n	Receiver Inverted Data Output	
19		GND	Ground	1
20		GND	Ground	1
21	CML-O	Rx2n	Receiver Inverted Data Output	
22	CML-O	Rx2p	Receiver Non-Inverted Data Output	
23		GND	Ground	1
24	CML-O	Rx4n	Receiver Inverted Data Output	1
25	CML-O	Rx4p	Receiver Non-Inverted Data Output	
26		GND	Ground	1
27	LVTTL-O	ModPrsL	Module Present	
28	LVTTL-O	IntL	Interrupt	
29		VccTx	+3.3 V Power Supply transmitter	2
30		Vcc1	+3.3 V Power Supply	2
31	LVTTL-I	LPMODE	Low Power Mode	
32		GND	Ground	1
33	CML-I	Tx3p	Transmitter Non-Inverted Data Input	
34	CML-I	Tx3n	Transmitter Inverted Data Output	
35		GND	Ground	1
36	CML-I	Tx1p	Transmitter Non-Inverted Data Input	

37	CML-I	Tx1n	Transmitter Inverted Data Output	
38		GND	Ground	1

Notes:

1. GND is the symbol for signal and supply (power) common for QSFP+ modules. All are common within the QSFP+ module and all module voltages are referenced to this potential unless otherwise noted. Connect these directly to the host board signal common ground plane.

2. VccRx, Vcc1 and VccTx are the receiving and transmission power suppliers and shall be applied concurrently. Recommended host board power supply filtering is shown in Figure 3 below. Vcc Rx, Vcc1 and Vcc Tx may be internally connected within the QSFP+ transceiver module in any combination. The connector pins are each rated for a maximum current of 500mA.

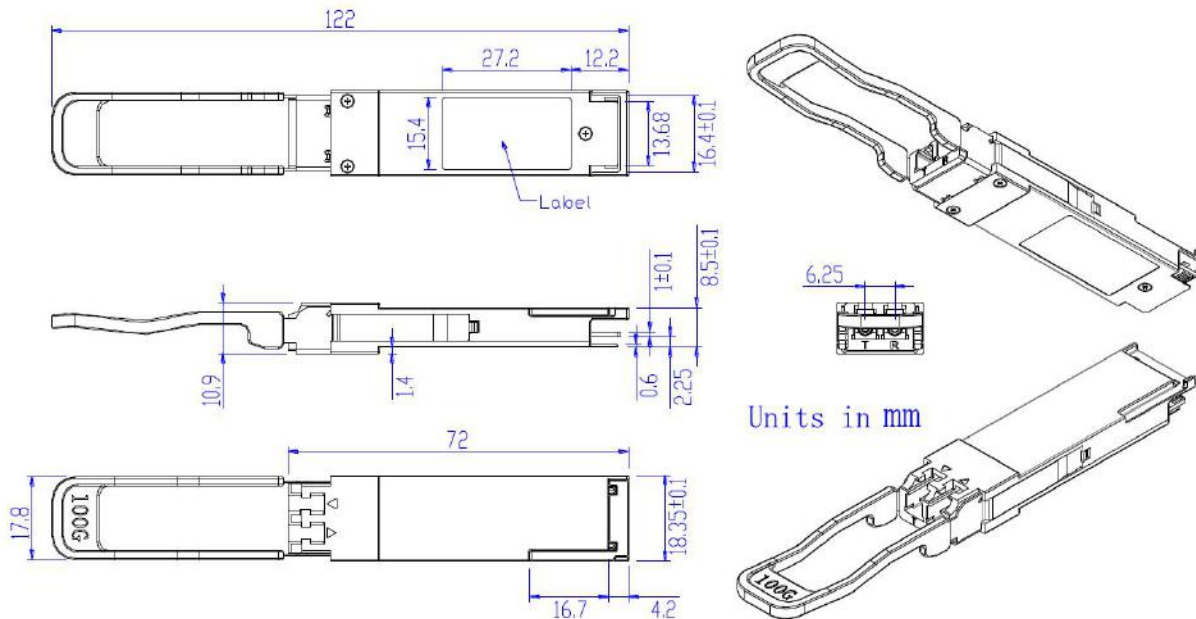
Mechanical Dimensions

ESD

This transceiver is specified as ESD threshold 1kV for SFI pins and 2kV for all other electrical input pins, tested per MIL-STD-883, Method 3015.4 /JESD22-A114-A (HBM). However, normal ESD precautions are still required during the handling of this module. This transceiver is shipped in ESD protective packaging. It should be removed from the packaging and handled only in an ESD protected environment.

Laser Safety

This is a Class 1 Laser Product according to IEC 60825-1:2007. This product complies with 21 CFR 1040.10 and 1040.11 except for deviations pursuant to Laser Notice No. 50, dated (June 24, 2007).

Ordering Information

GNQ3L0C04	QSFP28 CWDM4 2km optical transceiver with full real- time digital diagnostic monitoring and pull tab
-----------	--