

GCS5L0C43

1000BASE-BX SFP 1490nmTX/1310nmRX 40km DOM

Transceiver

Features

- Operating data rate Up to 1.25Gb/s
- Two types:
 - A: 1310nmDFB transmitter /1490nm receiver
 - B: 1490nmDFB transmitter/1310nm receiver
- Up to 40km on 9/125 μ m SMF
- Hot-pluggable SFP footprint
- BIDI LC/UPC type pluggable optical interface
- Low power dissipation
- Metal enclosure, for lower EMI
- RoHS compliant and lead-free
- Support Digital Diagnostic Monitor interface
- Single +3.3V power supply
- Case operating temperature:
 - Commercial: 0 $^{\circ}$ C ~ 70 $^{\circ}$ C
 - Extended: -20 $^{\circ}$ C ~ 85 $^{\circ}$ C
 - Industrial: -40 $^{\circ}$ C ~ 85 $^{\circ}$ C
- Compliant with SFP MSA Specification
- Compliant with SFF-8472
- Compliant with IEEE 802.3ah

Application

- Switch to Switch Interface
- Fast Ethernet
- Switched Backplane Applications
- Router/Server Interface
- Other Optical Links

Description

Gearlink’s SFP-GE-BX40 SFP transceiver is compatible with the Small Form Factor Pluggable Multi-Sourcing Agreement (MSA). The transceiver consists of five sections: the LD driver, the limiting amplifier, the digital diagnostic monitor, the 1310nm FP laser (the 1490nm DFB laser) and the PIN/TIA. The module data link up to 40km in 9/125um Single-mode fiber.

This transceiver meets the Small Form Pluggable (SFP) industry standard package utilizing an integral LC-Bi-directional optical interface connector. An enhanced Digital Diagnostic Monitoring Interface compliant with SFF-8472 has been incorporated into the transceiver. It allows real time access to the transceiver operating parameters such as transceiver temperature, laser bias current, transmitted optical power, received optical power and transceiver supply voltage by reading a built-in memory with I²C interface.

The optical output can be disabled by a LVTTTL logic high-level input of Tx Disable, and the system also can disable the module via I²C. Tx Fault is provided to indicate that degradation of the laser. Loss of signal (LOS) output is provided to indicate the loss of an input optical signal of receiver or the link status with partner. The system can also get the LOS (or Link)/Disable/Fault information via I²C register access.

Product Specifications

General Specifications

Parameter	Symbol	Min	Typ.	Max	Unit
Bit Rate	BR			1.25	Gb/sec
Max.Supported Link Length	Lmax			40	km

Absolute Maximum Ratings

Parameter	Symbol	Min	Typ.	Max	Unit	Ref.
Storage Temperature	T _s	-40		85	°C	
Storage Ambient Humidity	H _A	5		95	%	
Power Supply Voltage	V _{CC}	-0.5		4	V	
Signal Input Voltage		-0.3		V _{CC} +0.3	V	
Receiver Damage Threshold		+3			dBm	
Lead Soldering Temperature/Time	T _{sold}			260/10	°C/sec	Note 1
Lead Soldering Temperature/Time	T _{sold}			360/10	°C/sec	Note 2

Notes:

- 1.Suitable for wavesoldering.
- 2.Only for soldering by iron.

Electrical Characteristics

Parameter	Symbol	Min	Typ.	Max	Unit	Ref.	
Case Operating Temperature	Tcase	0		70	°C	GCS5L0C43(B34) - C	
		-20		85		GCS5L0C43(B34) - E	
		-40		85		GCS5L0C43(B34) - I	
Ambient Humidity	H _A	5		70	%	Non-condensing	
Power Supply Voltage	V _{CC}	3.13	3.3	3.47	V		
Power Supply Current	I _{CC}			280	mA		
Data Rate			1250/1250		Mbps	TX Rate/RX Rate	
Transmission Distance				40	km		
Coupled Fiber	Single mode fiber						9/125μm G.652
Transmitter							
Total Supply Current	I _{CC}			A	mA	Note 1	
Transmitter Disable Input-High	V _{DISH}	2		V _{CC} +0.3	V	LVTTL	
Transmitter Disable Input-Low	V _{DISL}	0		0.8	V	LVTTL	
Transmitter Fault Input-High	V _{TXFH}	2		V _{CC} +0.3	V	LVTTL	
Transmitter Fault Input-Low	V _{TXFL}	0		0.8	V	LVTTL	
Receiver							
Total Supply Current	I _{CC}			B	mA	Note 1	
LOS Output Voltage- High	V _{LOSH}	2		V _{CC} +0.3	V	LVTTL	
LOS Output Voltage- Low	V _{LOSL}	0		0.8	V	LVTTL	

Note:

1.A (TX) + B (RX) = 280mA (Not include termination circuit)

Optical Characteristics

Parameter	Symbol	Min	Typ.	Max	Unit	Ref.
Transmitter (Tx)						
Average Output Power	P _{OUT}	-5		0	dBm	GCS5L0C34
		-5		0		GCS5L0C43
Extinction Ratio	ER	9			dB	
Center Wavelength	λ _C	1260	1310	1360	nm	GCS5L0C34
		1470	1490	1510		GCS5L0C43
Spectrum Width (RMS)	σ			3.5	nm	FP Laser(TX:1310nm)
Side Mode Suppression Ratio	SMSR	30			dB	DFB Laser(TX:1490nm)
Spectrum Bandwidth(-20dB)	σ			1	nm	
Transmitter OFF Output Power	P _{OFF}			-45	dBm	

Jitter p-p	t_j			0.1	UI	Note 1
Output Eye Mask	Compliant with IEEE802.3 z (class 1 laser safety)					Note 2
Receiver (Rx)						
Input Optical Wavelength	λ_{IN}	1440	1490	1540	nm	GCS5L0C34
		1290	1310	1330		GCS5L0C43
Receiver Sensitivity	P_{IN}			-23	dBm	Note 3
Input Saturation Power (Overload)	P_{SAT}	-3			dBm	
Loss of Signal Assert	P_A	-45			dBm	
Loss of Signal De- assert	P_D			-23.5	dBm	Note 4
LOS Hysteresis	P_D-P_A	0.5		6	dB	

Notes:

1. Measure at 2⁷-1 NRZ PRBS pattern.
2. Transmitter eye mask definition.

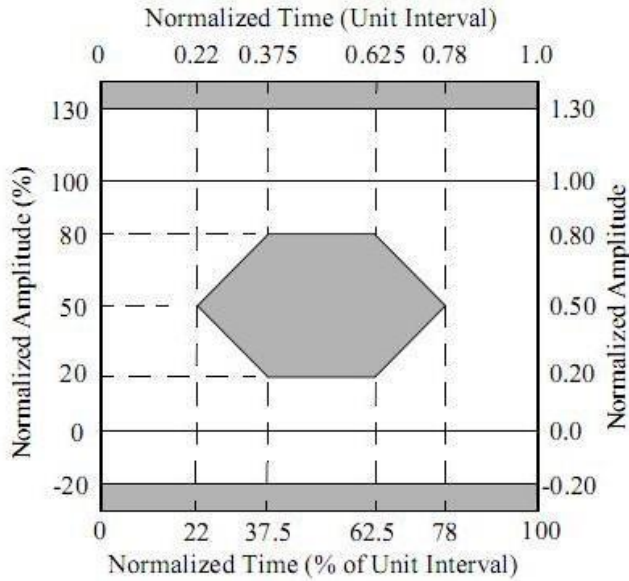

3. Measured with Light source 1490nm(1310nm), ER=9dB; BER = 10^{-12} @ PRBS=2⁷-1 NRZ.
4. When LOS De-asserted, the RX data +/- output is signal output.

Digital Diagnostic Memory Map

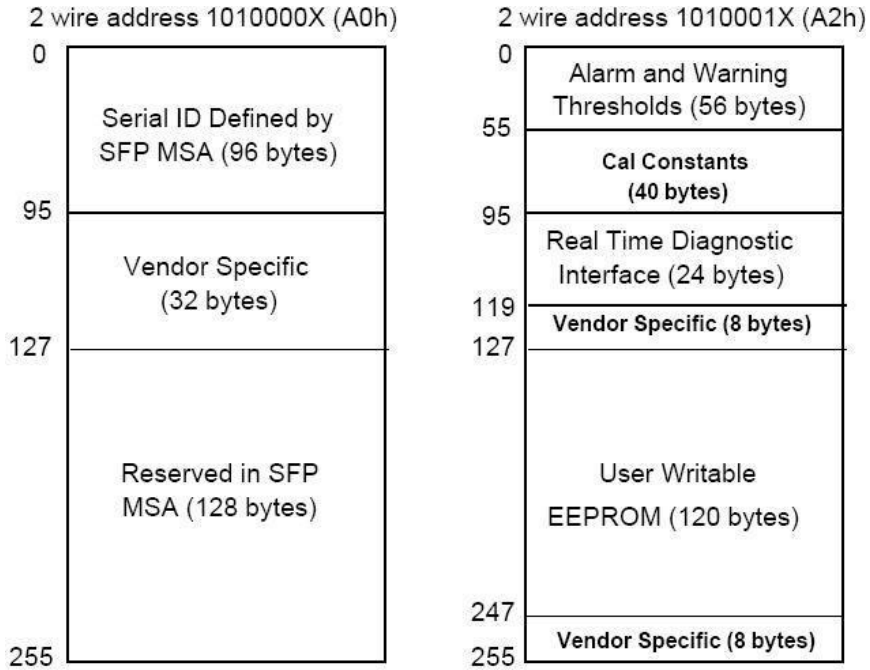

Digital Diagnostic Monitoring Information

Parameter	Unit	Accuracy
Case Temperature	°C	±3
Supply Voltage	V	±3%
TX Bias Current	mA	±10%
TX Optical Power	dB	±3
RX Optical Power	dB	±3

Pin Description

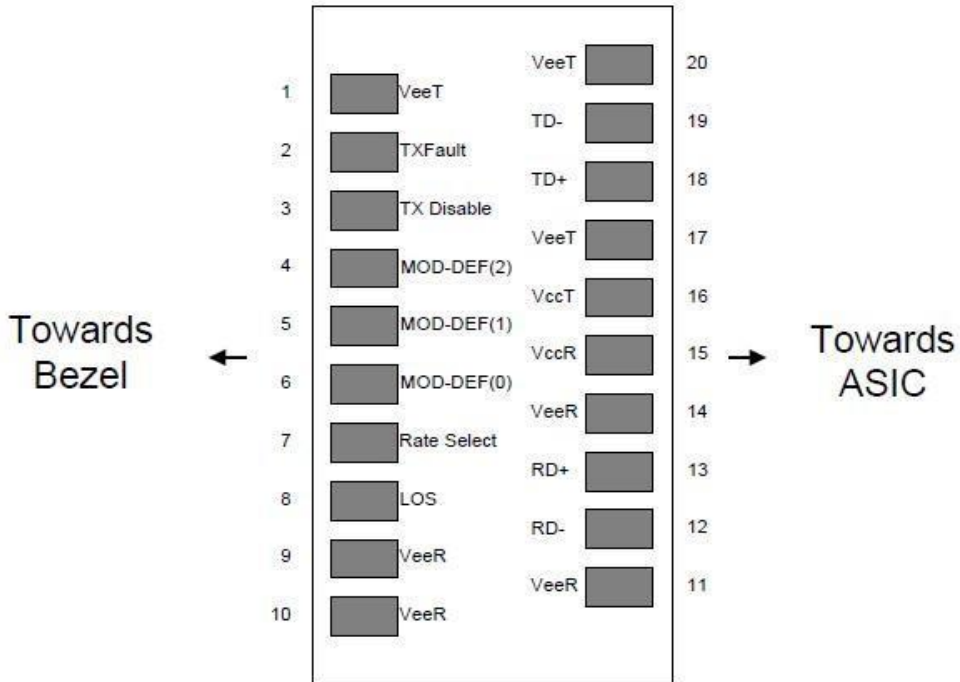

Figure 1. Pin out of Connector Block on Host Board

Pin	Symbol	Name/Description	Ref.
1	V _{EET}	Transmitter Ground (Common with Receiver Ground)	1
2	T _{FAULT}	Transmitter Fault.Open Drain. Logic “0” indicates normal operation.	2
3	T _{DIS}	Transmitter Disable. Laser output disabled on high or open.	3
4	MOD_DEF(2)	Module Definition 2. Data line for Serial ID.	4
5	MOD_DEF(1)	Module Definition 1. Clock line for Serial ID.	4
6	MOD_DEF(0)	Module Definition 0. Grounded within the module.	4
7	Rate Select	No connection required.	
8	LOS	Loss of Signal indication. Open Drain. Logic “0” indicates normal operation.	5
9	V _{EER}	Receiver Ground (Common with Transmitter Ground)	1
10	V _{EER}	Receiver Ground (Common with Transmitter Ground)	1
11	V _{EER}	Receiver Ground (Common with Transmitter Ground)	1
12	RD-	Receiver Inverted DATA out(CML). AC Coupled	
13	RD+	Receiver Non-inverted DATA out(CML). AC Coupled	
14	V _{EER}	Receiver Ground (Common with Transmitter Ground)	1
15	V _{CCR}	Receiver Power Supply	
16	V _{CCT}	Transmitter Power Supply	
17	V _{EET}	Transmitter Ground (Common with Receiver Ground)	1
18	TD+	Transmitter Non-Inverted DATA in. AC Coupled.	

19	TD-	Transmitter Inverted DATA in. AC Coupled.	
20	V _{EET}	Transmitter Ground (Common with Receiver Ground)	1

Notes:

1.Circuit ground is internally isolated from chassis ground.

2.TX Fault is an open drain output, which should be pulled up with 4.7K – 10KΩ resistor on the host board. Pull up voltage between 2.0V to VccT/R+0.3V. When high, output indicates < 0.8V. When sensing an improper power level in the laser driver, the SFP sets this signal high and turns off the laser. TX-FAULT can be reset with the TX-DISABLE line. The signal is in LVTTTL level.

3.TX disable is an input that is used to shut down the transmitter optical output. It is pulled up within the module with 4.7K – 10KΩ resistor. Its states are: Low (0 – 0.8V): Transmitter on; (>0.8, < 2.0V): Undefined; High (2.0V to VccT/R+0.3V): Transmitter Disabled; Open: Transmitter Disabled. The TX-DISABLE signal is high (LVTTTL logic “1”) to turn off the laser output. The laser will turn on when TX- DISABLE is low (LVTTTL logic “0”).

4.Should be pulled up with 4.7K - 10KΩ on host board to a voltage between 2.0V to VccT/R+0.3V. MOD_DEF (0) pulls line low to indicate module is plugged in.

5.LOS (Loss of Signal) is an open collector/drain output, which should be pulled up with 4.7K – 10KΩ resistor. Pull up voltage between 2.0V to VccT/R+0.3V. When high, this output indicates the received optical power is below the worst-case receiver sensitivity (as defined by the standard in use). Low indicates normal operation. In the low state, the output will be pulled to < 0.8V. The RX-LOS is high (LVTTTL logic “1”) when there is no incoming light from the companion transceiver. This signal is normally used by the system for the diagnostic purpose. The signal is operated in LVTTTL level.

Recommend Circuit Schematic

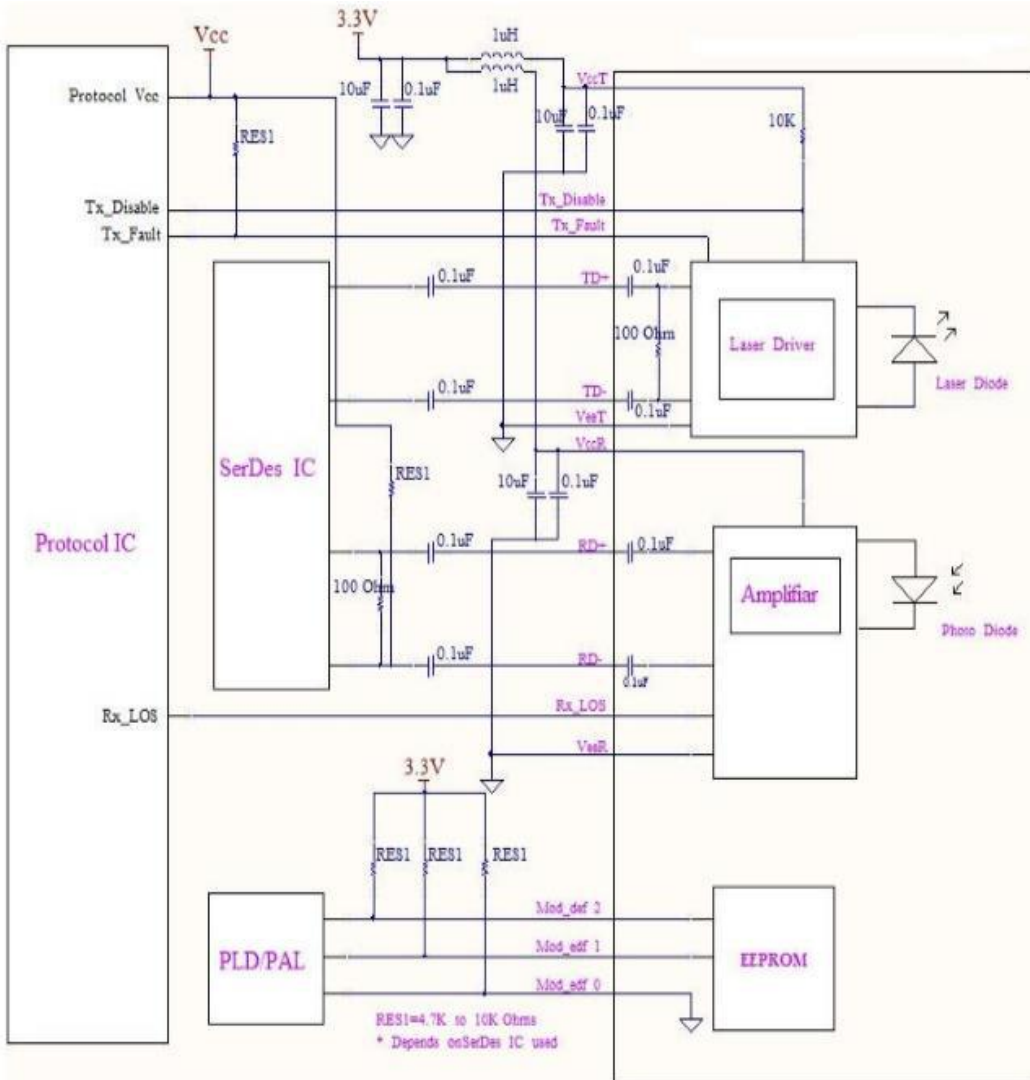

Mechanical Specifications

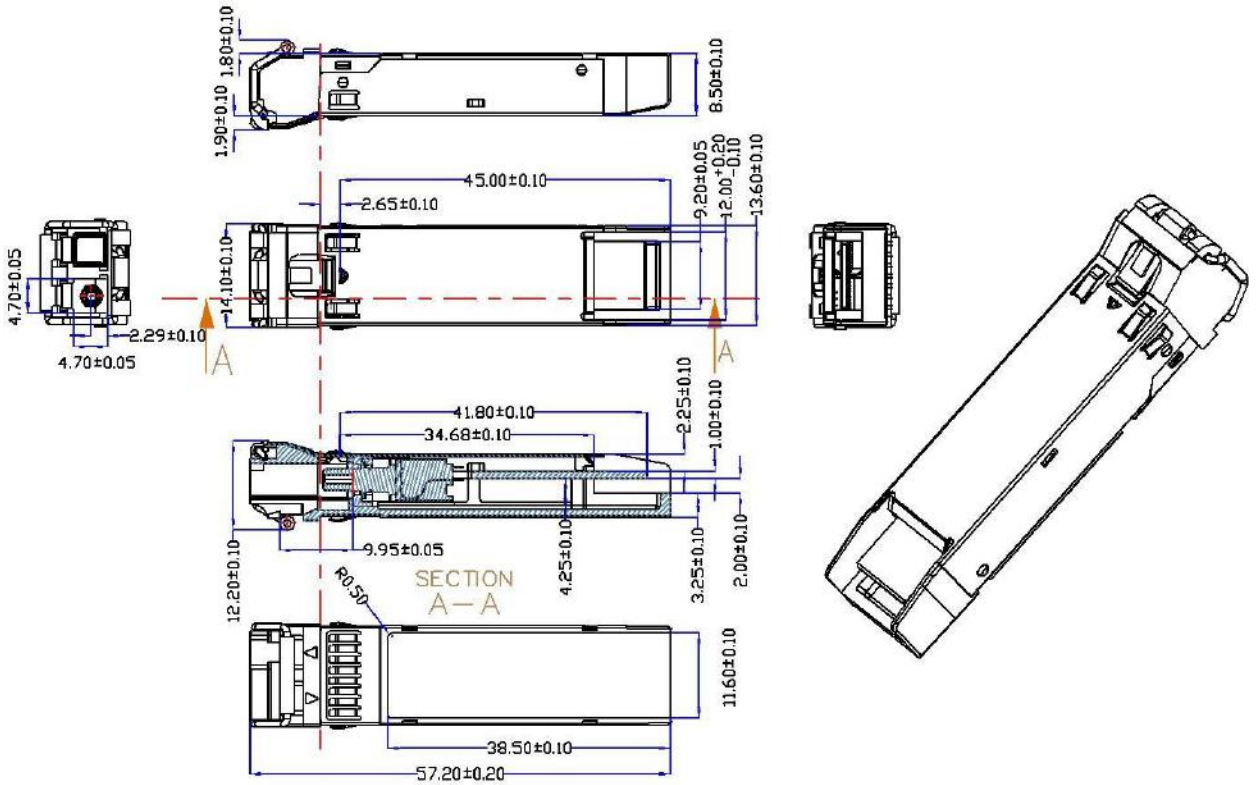

Order Information

Part Number	Description
GCS5L0C43	SFP, BIDI, 1000Base, 1490TX/1310nmRX, SMF, 40km, LC simplex, DOM