

GHS5L0C31

10Gb/s SFP+ ER Optical Transceiver

Features

- Compliant to SFP+ MSA
- Fully RoHS Compliant
- All metal housing for superior EMI performance
- IPF compliant mechanics (SFF-8432 Rev 4.3)
- Operating data rate 8.5-10.51875Gbps
- Uncooled 1310nm DFB Laser
- High sensitivity PIN photodiode and TIA
- Up to 40Km
- LC duplex connector
- Hot pluggable 20pin connector
- Low power consumption <1.0W
- 0oCto 70oCoperating wide temperature range
- Single +3.3V±5% power supply
- Digital Monitoring SFF-8472 Rev
- 10.2 compliant
- Real time monitoring of:



Application

- 10GBASE-LR/LW 10G Ethernet
- 10GFC
- 8GFC

General Description

The GHS5L0C31 1310nm DFB 10Gigabit Transceiver is designed to transmit and receive serial optical data over single mode optical fiber with 40Km. They are compliant with SFF-8431, SFF-8432, 10GFC Rev 4.0, FC-PI-4 Rev 7.0 and IEEE802.3ae 10GBASE-ER/LW. The transmitter converts serial CML electrical data into serial optical data compliant with the IEEE 802.3ae standard. An open collector compatible Transmit Disable (Tx_Dis) is provided. When TX_DIS is asserted High, Transmitter is turned off. The receiver converts serial optical data into serial CML electrical data. An open collector compatible Loss of Signal is provided. The RX_LOS signal indicates insufficient optical power for reliable signal reception at the receiver. Digital diagnostics functions are available via a 2-wire serial interface, as specified in SFF-8472 .

Block diagram

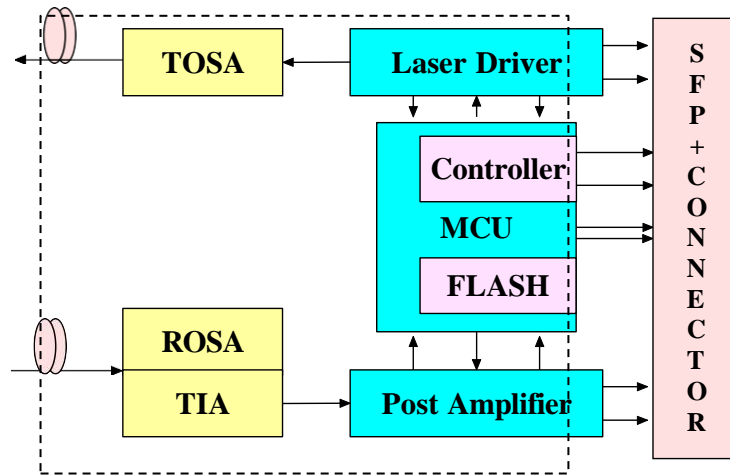

Parameter	Symbol	Unit	Min	Typ	Max	Note
Operating Case Temperature Range	Tc	°C	0		70	
Power Supply Voltage	Vcc	V	3.14	3.3	3.46	
Bit Rate	BR	Gb/s		9.953		10GBASE-LW
				10.3125		10GBASE-LR
				8.5		800-SM-LC-L
				10.51875		1200-SM-LL-L
Bit Error Ratio	BER				10 ⁻¹²	
Max Supported Link Length	L	Km			10	

Absolute Maximum Ratings

Parameter	Symbol	Unit	Min	Max
Storage Temperature Range	Ts	°C	-40	85
Relative Humidity	RH	%	0	95

Recommended Operating Conditions

Electrical Characteristics(Tc=0 °C to 70 °C and Vcc= 3.14 to 3.46)

Parameter	Symbol	Unit	Min	Typ	Max	Note
Supply Voltage	VCC	V	3.14	3.3	3.46	
Supply Current	Icc	mA			285	
Transmitter						
Input Differential Impedance	RIN	Ω	80	100	120	
Differential Data Input Swing	VIN	mVp-p	180		700	
Transmit Disable Voltage	VDIS	V	2		VCCHOST	

Transmit Enable Voltage	VEN	V	VEE		VEE +0.8	
Transmit Fault Assert Voltage	VFA	V	2.2		VCCHOST	
Transmit Fault De-Assert Voltage	VFDA	V	VEE		VEE +0.4	
Receiver						
Differential Data Output Swing	VOD	mVp-p	450	600	850	
Output Rise Time	tRISE	pS	25			
Output Fall Time	tFALL	pS	25			
LOS Fault	VLOSFT	V	2		VCCHOST	
LOS Normal	VLOSNR	V	VEE		VEE +0.8	

Optical Characteristics (Tc=0 °C to 70 °C and Vcc= 3.14 to 3.46)

Parameter	Symbol	Unit	Min	Typ	Max	Note
Transmitter						
Nominal Wavelength	λ_{TRP}	nm	1260	1310	1355	
Side Mode Suppression Ratio	SMSR	dB	30			
Optical Modulation Amplitude	POMA	dBm	-5.4			
Optical Output Power	Pav	dBm	-2		+3	
Extinction Ratio	ER	dB	3.5			
Transmitter and Dispersion Penalty	TDP	dB			3.2	
Launch Power in OMA Minus TDP		dBm	-6.2			
Average Launch Power of OFF Transmitter	POFF	dBm			-35	
Relative Intensity Noise	RIN	dB/Hz			-128	
Optical Return Loss Tolerance	ORLT	dB			12	
Receiver						
Center Wavelength	λ_C	nm	1260	1310	1610	
Average Receiver Power	P _{AVG}	dBm	-16		+0.5	
Receiver Sensitivity (OMA)	R _{SENSE1}	dBm			-12.6	1
Stressed Receiver Sensitivity (OMA)	R _{SENSE2}	dBm			-10.3	2
Receiver Reflectance	R _{REFL}	dB			-12	
Receive Electrical 3 dB Upper Cutoff Frequency	F _{CUT}	GHz			12.3	
LOS Assert LOS	LOSD	dBm	-30			
LOS De-Assert LOS	LOSA	dBm			-17	
LOS Hysteresis		dB	0.5			

Note:

1.Sensitivity for 10G PRBS 2³¹-1 and BER better than or equal to 10E-12

2.The stressed sensitivity value in the table are for system level BER measurements which include the effects of CDR circuit.

Pin Assignment

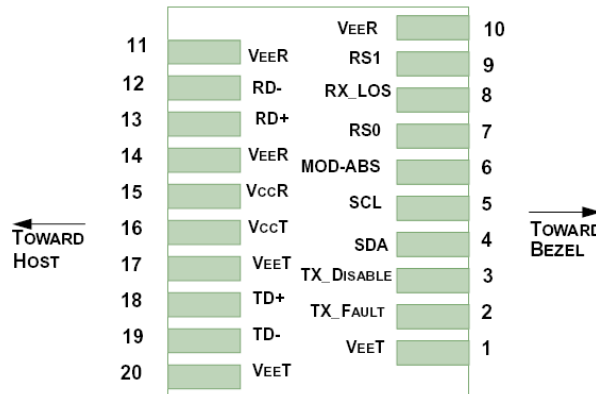

Pin Description

Pin Number	Symbol	Name	Description
1,17,20	VeeT	Transmitter Signal Ground	These pins should be connected to signal ground on the host board.
2	TX Fault	Transmitter Fault Out (OC)	Logic “1” Output = Laser Fault (Laser off before t_fault) Logic “0” Output = Normal Operation This pin is open collector compatible, and should be pulled up to Host Vcc with a 10kΩ resistor. Logic “1” Input (or no connection) = Laser off
3	TX Disable	Transmitter Disable In (LVTTTL)	Logic “0” Input = Laser on This pin is internally pulled up to VccT with a 10kΩ resistor.
4	SDA		
5	SCL	Module Definition Identifiers	Serial ID with SFF 8472 Diagnostics Module Definition pins should be pulled up to Host Vcc with 10 kΩ resistors.
6	MOD-ABS		
7	RS0	Receiver Rate Select (LVTTTL)	These pins have an internal 30kΩ pull-down to ground. A signal on either of these pins will not affect module performance.
9	RS1	Transmitter Rate Select (LVTTTL)	
			Sufficient optical signal for potential BER < 1x10 ⁻¹² = Logic “0”
8	LOS	Loss of Signal Out (OC)	Insufficient optical signal for potential BER < 1x10 ⁻¹² = Logic “1” This pin is open collector compatible, and should be pulled up to Host Vcc with a 10kΩ resistor.
10,11,14	VeeR	Receiver Signal Ground	These pins should be connected to signal ground on the host board.
12	RD-	Receiver Negative DATA Out (CML)	Light on = Logic “0” Output Receiver DATA output is internally AC coupled and series terminated with a 50Ω resistor.
13	RD+	Receiver Positive DATA Out (CML)	Light on = Logic “1” Output Receiver DATA output is internally AC coupled and series terminated with a 50Ω resistor.
15	VccR	Receiver Power Supply	This pin should be connected to a filtered +3.3V power supply on the host board. See Figure 3. Recommended power supply filter
16	VccT	Transmitter Power Supply	This pin should be connected to a filtered +3.3V power supply on the host board. See Figure 3. Recommended power supply filter
18	TD+	Transmitter Positive DATA In (CML)	Logic “1” Input = Light on Transmitter DATA inputs are internally AC coupled and terminated with a differential 100Ω resistor.
19	TD-	Transmitter Negative DATA In (CML)	Logic “0” Input = Light on Transmitter DATA inputs are internally AC coupled and terminated with a differential 100Ω resistor.

Typical application circuit

Recommended “Typical Application Schematics” are shown in Figure 3.

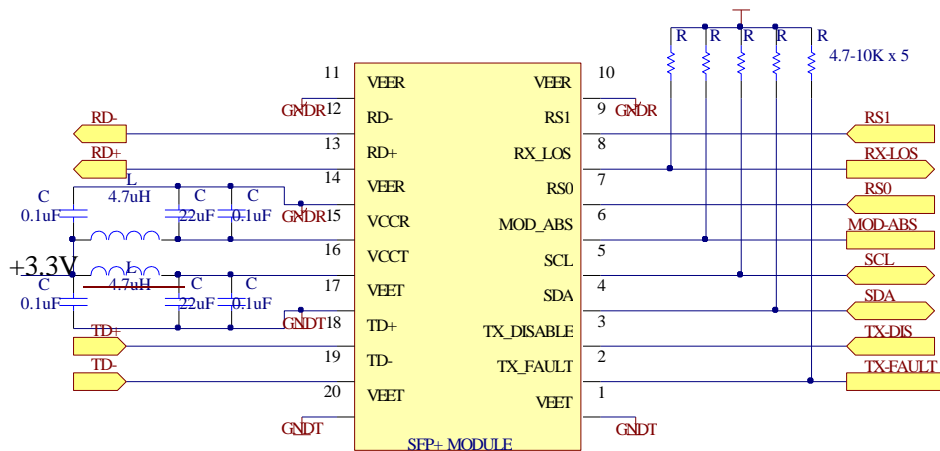

ESD

The GHS5L0C31 is compatible with ESD levels found in typical manufacturing and operating environments as described in Table 2. In the normal handling and operation of optical transceivers, ESD is of concern in two circumstances.

The first case is during handling of the transceiver prior to insertion into an SFP+ compliant cage. To protect the device, it’s important to use normal ESD handling pre-cautions. These include use of grounded wrist straps, work-benches and floor wherever a transceiver is handled.

The second case to consider is static discharges to the exterior of the host equipment chassis after installation. If the optical interface is exposed to the exterior of host equipment cabinet, the transceiver may be subject to system level ESD requirements.

EMI

Equipment incorporating gigabit transceivers is typically subject to regulation by the FCC in the United States, CENELEC EN55022 (CISPR 22) in Europe and VCCI in Japan. The GHS5L0C31 compliance to these standards is detailed in Table 2. The metal housing and shielded design of the GHS5L0C31 minimizes the EMI challenge facing the equipment designer.

EMI Immunity (Susceptibility)

Due to its shielded design, the EMI immunity of the GHS5L0C31 exceeds typical industry standards.

Regulatory compliance

Feature	Test Method	Performance
Electrostatic Discharge (ESD) to the Electrical Pins	MIL-STD-883C Method 3015.7	Class 1 (> 1500 Volts)
Electrostatic Discharge (ESD) to the Duplex LC Receptacle	Variation of IEC61000-4-2	Typically, no damage occurs with 15 kV when the duplex LC connector receptacle is contacted by a Human Body Model probe.
Electrostatic Interference (EMI)	CISPR22 ITE Class B	Compliant with standards
	EN55022 Class B FCC Class B	
Immunity	IEC61000-4-3 Class 2 EN55024	Typically show no measurable effect from a 3V/m field swept from 80 to 1000MHz applied to the transceiver without a chassis enclosure.
RoHS Compliance		Less than 1000 ppm of cadmium, lead, mercury, hexavalent chromium, polybrominated biphenyls, and polybrominated biphenyl ethers.

Digital Diagnostic Interface Definition

The 2-wire serial interface addresses of the SFP+ module are 1010000x (A0h) and 1010001x (A2h).

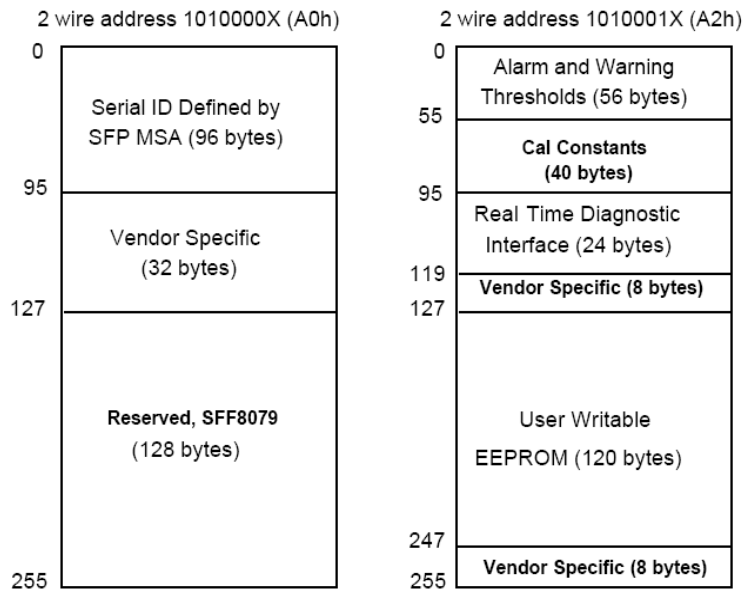

Serial ID Memory Contents

Accessing Serial ID Memory uses the 2 wire address 1010000X (A0). Memory Contents of Serial ID are shown in following.

Data Address	Size (Bytes)	Name of Field	Contents(Hex)	Description
Base ID Fields				
0	1	Identifier	03	SFP+
1	1	Ext. Identifier	04	SFP function is defined by serial ID only
2	1	Connector	07	LC Connector
3-10	8	Transceiver		Transceiver Codes
11	1	Encoding	03	NRZ
12	1	BR, Nominal	64	8.5-10.52Gbit/s
13	1	Reserved		
Data Address	Size (Bytes)	Name of Field	Contents(Hex)	Description
Base ID Fields				
0	1	Identifier	03	SFP+
1	1	Ext. Identifier	04	SFP function is defined by serial ID only
2	1	Connector	07	LC Connector
3-10	8	Transceiver		Transceiver Codes
11	1	Encoding	03	NRZ
12	1	BR, Nominal	64	8.5-10.52Gbit/s
13	1	Reserved		Transceiver transmit distance 10Km
14	1	Length (9μm) km	0A	
15	1	Length (9μm) 100m		
16	1	Length (50μm) 10m		
17	1	Length(62.5μm)10m		
18	1	Length (Copper)	00	Not compliant
19	1	Reserved	00	
20-35	16	Vendor name	4F 45 4D 20 20 20 20 20 20 20 20 20 20 20 20 20	“OEM”(ASCII)
36	1	Reserved	00	
37-39	3	Vendor OUI	00 00 00	“000000”
40-55	16	Vendor PN		Transceiver part number
56-59	4	Vendor rev	20 20 20 20	
60-61	2	Wavelength	05 1E	Transceiver wavelength
62	1	Reserved	00	
63	1	CC_BASE	Check Sum (Variable)	Check code for Base ID Fields
Extended ID Fields				
64-65	2	Options	00 1A	TX_DISABLE, TX_FAULT and Loss of Signal implemented.
66	1	BR,max	00	
67	1	BR,min	00	
68-83	16	Vendor SN	42 30 30 39 38 32 32 20	Serial Number of transceiver (ASCII). For

			20 20 20 20 20 20 20 20	example “B009822” .
84-91	8	Date code	00 00 00 00 00 00 000	Manufactory date code. For example “000000”.
92	1	Diagnostic Monitoring Type	68	Digital diagnostic monitoring implemented, “externally calibrated” is implemented, RX measurement type is “Average Power”.
93	1	Enhanced Options	F6	Optional Alarm/Warning flags implemented for all monitored quantities, Optional Soft TX_FAULT monitoring implemented, Optional Soft RX_LOS monitoring implemented.
94	1	SFF_8472 Compliance	03	Includes functionality described in Rev10.2 SFF-8472.
95	1	CC_EXT	Check Sum (Variable)	Check sum for Extended ID Field.
VENDOR SPECIFIC ID FIELDS				
96-127	32	Vendor Specific	Read only	Depends on customer information
128-255	128	Reserved	Read only	Filled by zero

Diagnostic Monitor Functions

Diagnostic Monitor Functions interface uses the 2 wire address 1010001X (A2). Memory contents of Diagnostic Monitor Functions are shown in Table 4

Table 4: Memory contents of Diagnostic Monitor Function

Data Address	Field Size (bytes)	Name	Contents and Description
Alarm and Warning Thresholds			
00-01	2	Temperature High Alarm	Set to 70 °C
02-03	2	Temperature Low Alarm	Set to -5 °C
04-05	2	Temperature High Warning	Set to 65 °C
06-07	2	Temperature Low Warning	Set to 0 °C
08-09	2	Vcc High Alarm	Set to 3.6 V
10-11	2	Vcc Low Alarm	Set to 3.0 V
12-13	2	Vcc High Warning	Set to 3.5 V
14-15	2	Vcc Low Warning	Set to 3.1 V
16-17	2	Bias High Alarm	2×IBias +20 (25°C)
18-19	2	Bias Low Alarm	25%×IBias (25°C)
20-21	2	Bias High Warning	2×IBias +10
22-23	2	Bias Low Warning	50%×IBias (25°C)
24-25	2	TX Power High Alarm	Manufacture measurement plus 2dB
26-27	2	TX Power Low Alarm	Manufacture measurement minus 2dB
28-29	2	TX Power High Warning	Manufacture measurement plus 1dB
30-31	2	TX Power Low Warning	Manufacture measurement minus 1dB
32-33	2	RX Power High Alarm	Maximum input optical power
34-35	2	RX Power Low Alarm	Minimum input optical power
36-37	2	RX Power High Warning	Maximum input power minus 3dB
38-39	2	RX Power Low Warning	Manufacture measurement plus 3dB
40-55	16	Reserved	

Calibration Constants			
56-59	4	RX Power Calibration Data4	Single precision floating-point numbers (various values at each device)
60-63	4	RX Power Calibration Data3	
64-67	4	RX Power Calibration Data2	
68-71	4	RX Power Calibration Data1	Single precision floating-point numbers (various values at each device)
72-75	4	RX Power Calibration Data0	
76-77	2	Bias Calibration Data1	00 01 (fixed)
78-79	2	Bias Calibration Data0	00 00 (fixed)
80-81	2	TX Power Calibration Data1	00 01 (fixed)
82-83	2	TX Power Calibration Data0	00 00 (fixed)
84-85	2	Temperature Calibration Data1	00 01 (fixed)
86-87	2	Temperature Calibration Data0	00 00 (fixed)
88-89	2	Vcc Calibration Data1	00 01 (fixed)
90-91	2	Vcc Calibration Data0	00 00 (fixed)
92-94	3	Reserved	00 00 00 (fixed)
95	1	Check Sum	Checksum of bytes 0-94
Real Time Diagnostic Monitor Interface			
96-97	2	Measured Temperature	Yield a 10-bit A/D value
98-99	2	Measured Vcc	Yield a 10-bit A/D value
100-101	2	Measured Bias	Yield a 10-bit A/D value
102-103	2	Measured TX Power	Yield a 10-bit A/D value
104-105	2	Measured RX Power	Yield a 10-bit A/D value
106-109	4	Reserved	
110	1	Logic Status	
111	1	AD Conversion Updates	
112-119	8	Alarm and Warning Flags	
Vendor Specific			
120-127	8	Vendor Specific	Don't Access
128-247	120	User writable EEPROM	
248-255	8	Vendor Specific	Don't Access

Transceiver Timing Characteristics ($T_c=0^{\circ}\text{C}$ to 70°C and $V_{ccT}, V_{ccR} = 3.145$ to 3.465)

Parameter	Symbol	Minimum	Maximum	Unit	Notes
Hardware TX_DISABLE Assert Time	t_off		10	μs	1
Hardware TX_DISABLE Negate Time	t_on		1	ms	2
Time to initialize including reset of TX_FAULT	t_init		300	ms	3
Hardware TX_FAULT Assert Time	t_fault		100	μs	4
Hardware TX_DISABLE to Reset	t_reset	10		μs	5
Hardware RX_LOS DeAssert Time	t_loss_on		100	μs	6
Hardware RX_LOS Assert Time	t_loss_off		100	μs	7

Software TX_DISABLE Assert Time	t_off_soft		100	ms	8
Software TX_DISABLE Negate Time	t_on_soft		100	ms	9
Software Tx_FAULT Assert Time	t_fault_soft		100	ms	10
Software Rx_LOS Assert Time	t_loss_on_soft		100	ms	11
Software Rx_LOS De-Assert Time	t_loss_off_soft		100	ms	12
Analog parameter data ready	t_data		1000	ms	13
Serial bus hardware ready	t_serial		300	ms	14
Write Cycle Time	t_write		10	ms	15
Serial ID Clock Rate	f_serial_clock		400	kHz	

Note :

1. Time from rising edge of TX_DISABLE to when the optical output falls below 10% of nominal.
2. Time from falling edge of TX_DISABLE to when the modulated optical output rises above 90% of nominal.
3. Time from power on or falling edge of Tx_Disable to when the modulated optical output rises above 90% of nominal.
4. From power on or negation of TX_FAULT using TX_DISABLE.
5. Time TX_DISABLE must be held high to reset the laser fault shutdown circuitry.
6. Time from loss of optical signal to Rx_LOS Assertion.
7. Time from valid optical signal to Rx_LOS De-Assertion.
8. Time from two-wire interface assertion of TX_DISABLE (A2h, byte 110, bit 6) to when the optical output falls below 10% of nominal. Measured from falling clock edge after stop bit of write transaction.
9. Time from two-wire interface de-assertion of TX_DISABLE (A2h, byte 110, bit 6) to when the modulated optical output rises above 90% of nominal.
10. Time from fault to two-wire interface TX_FAULT (A2h, byte 110, bit 2) asserted.
11. Time for two-wire interface assertion of Rx_LOS (A2h, byte 110, bit 1) from loss of optical signal.
12. Time for two-wire interface de-assertion of Rx_LOS (A2h, byte 110, bit 1) from presence of valid optical signal.
13. From power on to data ready bit asserted (A2h, byte 110, bit 0). Data ready indicates analog monitoring circuitry is functional.
14. Time from power on until module is ready for data transmission over the serial bus (reads or writes over A0h and A2h).
15. Time from stop bit to completion of a 1-8 byte write command.

Ordering Information

GHS5L0C31	SFP+ LR 40km optical transceiver with operating temperature 0°C~70°C
-----------	--