

## GAS5LOC31

### SFP 155M 1310nm 40Km LC

#### Features

- Duplex LC receptacle optical interface
- Single +3.3V power supply
- Hot-pluggable
- AC coupling of PECL signals
- Serial ID module on MOD (0-2)
- DDM Function implemented
- External Calibration
- International Class 1 laser safety certified
- Transmitter disable input
- Receiver Loss of Signal Output
- Operating temperature range: -0°C~+70°C
- Compliant with RoHS

#### Applications

- SDH/ STM-1, SONET/OC-3
- Metropolitan area network
- Fast Ethernet
- Other optic link

#### Standards

- Compliant with SFP MSA (INF-8074i)
- Compliant with ITU-T G.957 STM-1
- Compliant with SFF-8472 v9.3

#### Absolute Maximum Ratings

Parameter	Symbol	Unit	Min	Typ	Max
Case Operating Temperature Range	T <sub>c</sub>	°C	-10		70
Power Supply Voltage	V <sub>cc</sub>	V	3.135	3.3	3.465
Data rate		Mb/s	-	155.52	-

#### Recommended Operating Conditions

Parameter	Symbol	Unit	Min	Max
Storage Temperature Range	T <sub>s</sub>	°C	-40	+85
Relative Humidity (without dew)	RH	%	8	80
Supply Voltage	V <sub>cc</sub>	V	-0.5	4

**Specifications (tested under recommended operating condition, unless otherwise noted)**

Parameter	Symbol	Min	Type	Max	Units	Notes
<b>Electrical Characteristics</b>						
Supply Current	I <sub>cc</sub>	-	-	300	mA	1
Transmitter Differential Input Voltage	V <sub>IN</sub>	300	-	2200	mV <sub>pp</sub>	
Receiver Differential Output Voltage	V <sub>O</sub>	600	-	1200	mV <sub>pp</sub>	
Transmit Fault (TX Fault)	V <sub>OH</sub>	2.0	-	V <sub>cc</sub>	V	
	V <sub>OL</sub>	0	-	0.8	V	
Loss of Signal (LOS)	V <sub>OH</sub>	2.0	-	V <sub>cc</sub>	V	
	V <sub>OL</sub>	0	-	0.8	V	
Transmitter Disable (TX-Disable)	V <sub>IH</sub>	2.0	-	V <sub>cc</sub>	V	
	V <sub>IL</sub>	0	-	0.8	V	
MOD-DEF1, 2	V <sub>IH</sub>	2.0	-	V <sub>cc</sub>	V	
<b>Optical transmitter Characteristics</b>						
Launched Power(avg.)	P <sub>o</sub>	-9	-5	-3	dBm	
Output center wavelength	c	1261	1310	1360	nm	
		1430	1550	1580	nm	
Output spectrum width		-	-	7.7	nm	RMS (1310nmFP-LD)
		-	-	1	nm	-20dB(1550nmDFB-LD)
SMSR (dB)		30	-	-		DFB-LD
Extinction ratio	ER	8.2	-	-	dB	
Output eye	Compliant with ITU-T G.957 STM-1 eye masks when filtered					
Optical rise/fall time	t <sub>r</sub> / t <sub>f</sub>	-	-	1.5	ns	
Transmitter jitter	T <sub>J</sub>			0.1	UI <sub>p-p</sub>	2
Relative intensity noise	RIN	-	-	-120	dB/Hz	3
P <sub>out</sub> TX-Disable Asserted	P <sub>off</sub>	-	-	-35	dBm	
<b>Optical receiver Characteristics</b>						
Sensitivity	S	-	-	-32	dBm	40km
		-	-30	-32	dBm	40km
Overload	P <sub>in</sub>	-8	-	-	dBm	
LOS	Optical decreased	-	-45	-	dB	
	Optical increased	-	-	-32	dB	
LOS hysteresis	-	0.5	3	5	dB	5

**Note:**

- The supply current includes SFP module's supply current and test board working current.
- For the jitter measurements, the device was driven with SONET OC-3 data pattern with 2<sup>23</sup>-1 PRBS payload..
- RIN is the laser noise, integrated over a specified bandwidth, measured relative to average optical power with 12dB return loss.
- Measured with a PRBS 2<sup>23</sup>-1 test pattern, @155Mb/s, EX=10dB, BER<10<sup>-10</sup>.
- The LOS Hysteresis to minimize "chatter" on the output line. In principle, Hysteresis alone does not guarantee chatter-free operation

**Digital Diagnostic Memory Map**

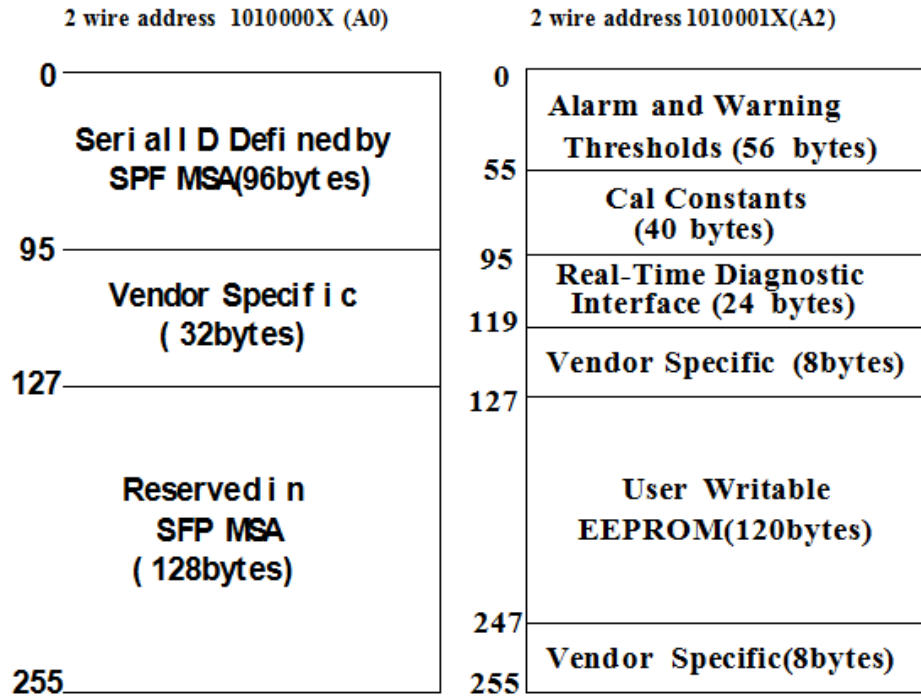

**EEPROM Serial ID Memory Contents**

Accessing Serial ID Memory uses the 2 wire address 1010000X (A0). Memory Contents of Serial ID are shown in the Table 1.

**Table 1 Serial ID Memory Contents**

Data Address	Size (Bytes)	Name of Field	Contents (Hex)	Description
<b>BASE ID FIELDS</b>				
0	1	Identifier	03	SFP
1	1	Ext. Identifier	04	SFP function is defined by serial ID only
2	1	Connector	07	LC Connector
3-10	8	Transceiver		Transceiver Codes
11	1	Encoding	03	NRZ
12	1	BR, Nominal	01	155Mbit/s
13	1	Reserved	00	
14	1	Length (9µm) km		Transceiver transmit distance
15	1	Length (9µm) 100m		
16	1	Length (50µm) 10m		
17	1	Length(62.5µm)10m		
18	1	Length (Copper)	00	Not compliant

19	1	Reserved	00	
20-35	16	Vendor name	4F 45 4D 20 20 20 20 20 20 20 20 20 20 20 20 20	“OEM” (ASCII)
36	1	Reserved	00	
37-39	3	Vendor OUI	00 00 00	
40-55	16	Vendor PN		Transceiver part number
56-59	4	Vendor rev	20 20 20 20	
60-61	2	Wavelength		Transceiver wavelength
62	1	Reserved	00	
63	1	CC_BASE	Check Sum (Variable)	Check code for Base ID Fields
<b>Extended ID Fields</b>				
64-65	2	Options	00 1A	TX_DISABLE, TX_FAULT and Loss of Signal implemented.
66	1	BR,max	00	
67	1	BR,min	00	
68-83	16	Vendor SN	42 30 30 39 38 32 32 20 20 20 20 20 20 20 20 20	Serial Number of transceiver (ASCII). For example “B009822”.
84-91	8	Date code	30 32 31 30 30 35 20 20	Manufactory date code. For example “021005”.
92	1	Diagnostic Monitoring Type	58	Digital diagnostic monitoring implemented, “externally calibrated” is implemented, RX measurement type is “AveragePower”.
93	1	Enhanced Options	B0	Optional Alarm/Warning flags implemented for all monitored quantities, Optional Soft TX_FAULT monitoring implemented, Optional Soft RX_LOS monitoring implemented.
94	1	SFF_8472 Compliance	01	Includes functionality described in Rev9.3 SFF-8472.
95	1	CC_EXT	Check Sum (Variable)	Check sum for Extended ID Field.
<b>Vendor Specific ID Fields</b>				
96-127	32	Vendor Specific	Read only	Depends on customer information
128-255	128	Reserved	Read only	Filled by zero

## Diagnostic Monitor Functions

Diagnostic Monitor Functions interface uses the 2 wire address 1010001X (A2). Memory contents of Diagnostic Monitor Functions are shown in Table 2

**Table 2 Memory contents of Diagnostic Monitor Function**

Data Address	Field Size (bytes)	Name	Contents and Description
<b>Alarm and Warning Thresholds</b>			
00-01	2	Temperature High Alarm	Set to 85 °C
02-03	2	Temperature Low Alarm	Set to -5 °C
04-05	2	Temperature High Warning	Set to 75 °C
06-07	2	Temperature Low Warning	Set to 0 °C
08-09	2	Vcc High Alarm	Set to 3.6 V
10-11	2	Vcc Low Alarm	Set to 3.0 V
12-13	2	Vcc High Warning	Set to 3.5 V
14-15	2	Vcc Low Warning	Set to 3.1 V
16-17	2	Bias High Alarm	$2 \times \text{IBias}(25\text{ }^{\circ}\text{C}) + 20$
18-19	2	Bias Low Alarm	$25\% \times \text{IBias}(25\text{ }^{\circ}\text{C})$
20-21	2	Bias High Warning	$2 \times \text{IBias}(25\text{ }^{\circ}\text{C}) + 10$
22-23	2	Bias Low Warning	$50\% \times \text{IBias}(25\text{ }^{\circ}\text{C})$
24-25	2	TX Power High Alarm	Manufacture measurement plus 2dB
26-27	2	TX Power Low Alarm	Manufacture measurement minus 2dB
28-29	2	TX Power High Warning	Manufacture measurement plus 1dB
30-31	2	TX Power Low Warning	Manufacture measurement minus 1 dB
32-33	2	RX Power High Alarm	Maximum input optical power
34-35	2	RX Power Low Alarm	Minimum input optical power
36-37	2	RX Power High Warning	Maximum input power minus 3dB
38-39	2	RX Power Low Warning	Manufacture measurement plus 3dB
40-55	16	Reserved	
<b>Calibration Constants</b>			
56-59	4	RX Power Calibration Data4	Single precision floating-point numbers (various values at each device)
60-63	4	RX Power Calibration Data3	
64-67	4	RX Power Calibration Data2	Single precision floating-point numbers (various values at each device)
68-71	4	RX Power Calibration Data1	
72-75	4	RX Power Calibration Data0	
76-77	2	Bias Calibration Data1	00 01 (fixed)
78-79	2	Bias Calibration Data0	00 00 (fixed)
80-81	2	TX Power Calibration Data1	00 01 (fixed)
82-83	2	TX Power Calibration Data0	00 00 (fixed)
84-85	2	Temperature Calibration Data1	00 01 (fixed)

86-87	2	Temperature Calibration Data0	00 00 (fixed)
88-89	2	Vcc Calibration Data1	00 01 (fixed)
90-91	2	Vcc Calibration Data0	00 00 (fixed)
92-94	3	Reserved	00 00 00 (fixed)
95	1	Check Sum	Checksum of bytes 0-94
<b>Real Time Diagnostic Monitor Interface</b>			
96-97	2	Measured Temperature	Yield to a 16-bit A/D value (see Table 3.1)
98-99	2	Measured Vcc	Yield a 16-bit A/D value (see Table 3.1)
100-101	2	Measured Bias	Yield a 16-bit A/D value (see Table 3.1)
102-103	2	Measured TX Power	Yield a 16-bit A/D value (see Table 3.1)
104-105	2	Measured RX Power	Yield a 16-bit A/D value (see Table 3.1)
106-109	4	Reserved	
110	1	Logic Status	See Table 3.2
111	1	AD Conversion Updates	See Table 3.2
112-119	8	Alarm and Warning Flags	See Table 3.3
<b>Vendor Specific</b>			
120-127	8	Vendor Specific	Don't Access
128-247	120	User writable EEPROM	
248-255	8	Vendor Specific	Don't Access

The measured values located at bytes 96-105 (in the 2 wire address 0xA2) are raw A/D values (16-bit integers) of transceiver temperature, supply voltage, laser bias current, laser optical output power and received power. All the measured values are “Externally Calibrated”, and then it is necessary to convert raw A/D values to real world units by the manner as shown in Table 3.1.

**Table 3.1 Real Time Diagnostic Monitor Values**

Byte	Name	Description
97	Temperature LSB	Internally measured supply voltage. Comply with External Calibration of SFF-8472.
98	Vcc MSB	
99	Vcc LSB	
100	Laser Bias MSB	Measured Laser bias current. Comply with External Calibration of SFF-8472.
101	Laser Bias LSB	
102	Tx Power MSB	Measured Tx power. Comply with External Calibration of SFF-8472.
103	Tx Power LSB	
104	Rx Power MSB	Measured Rx power. Comply with External Calibration of SFF-8472.
105	Rx Power LSB	

This transceiver implements two optional status bytes, “Logic States” at byte 110(0xA2)” and “A/D Updated” at byte 111(0xA2) as shown in Table 3.2. “A/D Updated” status bits allow the user to verify if an update from the analog-digital conversion has occurred of the measured values, temperature, Vcc, laser bias, Tx power and Rx power. The user writes the byte to 0x00. Once a conversion is completed for a given value, its bit will change to ‘1’.

**Table 3.2 Logic Status and AD Conversion Updates**

Byte	Bit	Name	Description
110	7	Tx Disable State	Optional digital State of the Tx Disable input pin.
110	6	Soft Tx Disable Control	Not supported (set to 0).
110	5	Reserved	Set to 0.
110	4	Rx Rate Select State	Not supported (set to 1).
110	3	Soft Rate Select Control	Not supported (set to 0).
110	2	Tx Fault	Optional digital state of the Tx Fault output pin.
110	1	LOS	Optional digital state of the LOS output pin.
110	0	Power on Logic	Bit will be 0 when the analog monitoring is active.
111	7	Temp A/D Valid	Indicates A/D value in Bytes 96/97 is valid.
111	6	Vcc A/D Valid	Indicates A/D value in Bytes 98/99 is valid.
111	5	Laser Bias A/D Valid	Indicates A/D value in Bytes 100/101 is valid.
111	4	Tx Power A/D Valid	Indicates A/D value in Bytes 102/103 is valid.
111	3	Rx Power A/D Valid	Indicates A/D value in Bytes 104/105 is valid.
111	2	Reserved	Set to 0.
111	1	Reserved	Set to 0.
111	0	Reserved	Set to 0.

Each of the measured values has a corresponding high alarm, low alarm, high warning and low warning threshold level at location 00-39(x0A2) written as the data format of a corresponding valued shown in Table 3.3 Alarm and warning flags at bytes 112-119(0xA2) are defined as follows.

- (1) Alarm flags indicate conditions likely to result (or have resulted) in link failure and cause for immediate action.
- (2) Warning flags indicate conditions outside the guaranteed operating specification of transceiver but not necessarily causes of immediate link failures.

**Table 3.3 Alarm and Warning Flags**

Byte	Bit(s)	Name	Description
112	7	Temperature High Alarm	Set when temperature monitor value exceeds high alarm level.
112	6	Temperature Low Alarm	Set when temperature monitor value exceeds low alarm level.
112	5	Vcc High Alarm	Set when Vcc monitor value exceeds high alarm level.
112	4	Vcc Low Alarm	Set when Vcc monitor value exceeds Low alarm level.
112	3	Laser Bias High Alarm	Set when laser bias monitor value exceeds high alarm level.
112	2	Laser Bias Low Alarm	Set when laser bias monitor value exceeds low alarm level.
112	1	Tx Power High Alarm	Set when Tx power monitor value exceeds high alarm level
112	0	Tx Power Low Alarm	Set when Tx power monitor value exceeds low alarm level.
113	7	Rx Power High Alarm	Set when Rx power monitor value exceeds high alarm level
113	6	Rx Power Low Alarm	Set when Rx power monitor value exceeds low alarm level

113	5-0	Reserved	All bits set to 0.
114	7-0	Reserved	All bits set to 0.
115	7-0	Reserved	All bits set to 0.
116	7	Temperature High warning	Set when temperature monitor value exceeds high warning level.
116	6	Temperature Low warning	Set when temperature monitor value exceeds low warning level.
116	5	Vcc High warning	Set when Vcc monitor value exceeds high warning level.
116	4	Vcc Low warning	Set when Vcc monitor value exceeds Low warning level.
116	3	Laser Bias High warning	Set when laser bias monitor value exceeds high warning level.
116	2	Laser Bias Low warning	Set when laser bias monitor value exceeds low warning level.
116	1	Tx Power High warning	Set when Tx power monitor value exceeds high warning level.
116	0	Tx Power Low warning	Set when Tx power monitor value exceeds low warning level.
117	7	Rx Power High warning	Set when Rx power monitor value exceeds high warning level.
117	6	Rx Power Low warning	Set when Rx power monitor value exceeds low warning level.
117	5-0	Reserved	All bits set to 0.
118	7-0	Reserved	All bits set to 0.
119	7-0	Reserved	All bits set to 0.

### Pin Description

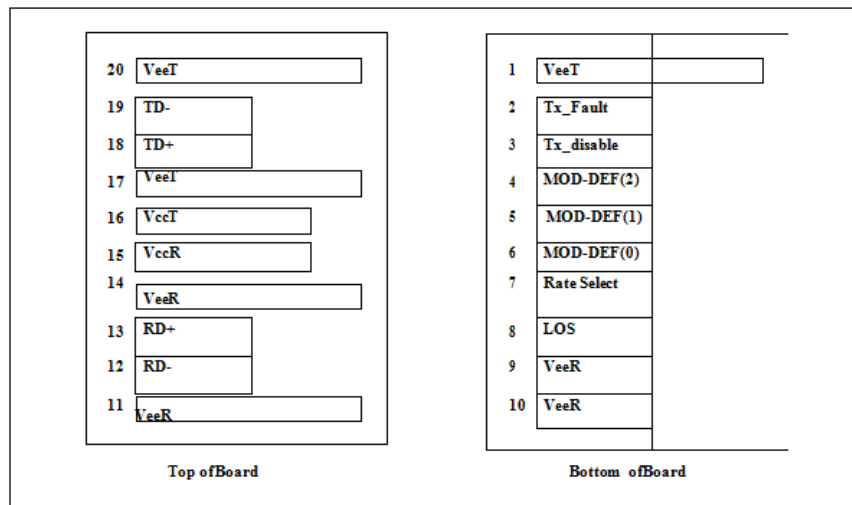

As Viewed Through Top of Board



Pin	Name	Function/Description	Engagement order	Notes
1	VeeT	Transmitter Ground	1	
2	TX Fault	Transmitter Fault Indication	3	1
3	TX Disable	Transmitter Disable-Module disables on high or open	3	2
4	MOD-DEF2	Module Definition 2-Two wire serial ID interface	3	3
5	MOD-DEF1	Module Definition 1-Two wire serial ID interface	3	3
6	MOD-DEF0	Module Definition 0-Two wire serial ID interface	3	3
7	Rate Select	Not Connected	3	
8	LOS	Loss of Signal	3	4
9	VeeR	Receiver Ground	1	
10	VeeR	Receiver Ground	1	
11	Veer	Receiver Ground	1	
12	RD-	Inverse Received Data out	3	5
13	RD+	Received Data out	3	5
14	VeeR	Receiver Ground	1	
15	VccR	Receiver Power — +3.3V±5%	2	6
16	VccT	Transmitter Power — +3.3 V±5%	2	6
17	VeeT	Transmitter Ground	1	
18	TD+	Transmitter Data In	3	7
19	TD-	Inverse Transmitter Data In	3	7
20	VeeT	Transmitter Ground	1	

**Note1.** TX Fault is open collector/drain output which should be pulled up externally with a 4.7K – 10KΩ resistor on the host board to supply <VccT+0.3V or VccR+0.3V. When high, this output indicates a laser fault of some kind. Low indicates normal operation. In the low state, the output will be pulled to <0.8V.

**Note2.** TX Disable input is used to shut down the laser output per the state table below. It is pulled up within the module with a 4.7 – 10K resistor.

Low (0 – 0.8V): Transmitter on Between (0.8V and 2V): Undefined  
 High (2.0 – VccT): Transmitter Disabled Open : Transmitter Disabled

**Note3.** Mod-Def 0, 1, 2. These are the module definition pins. They should be pulled up with a 4.7 - 10K resistor on the host board to supply less than VccT+0.3V or VccR+0.3V.

Mod-Def 0 is grounded by the module to indicate that the module is present. Mod-Def 1 is clock line of two wire serial interface for optional serial ID. Mod-Def 2 is data line of two wire serial interface for optional serial ID.

**Note4.** LOS (Loss of signal) is an open collector/drain output which should be pulled up externally with a 4.7 – 10K resistor on the host board to supply <VccT+0.3V or VccR+0.3V. When high, this output indicates the received optical power is below the worst case receiver sensitivity (as defined by the standard in use). Low indicates normal operation. In the low state, the output will be pulled to <0.8V.

**Note5.** RD-/+ : These are the differential receiver outputs. They are AC coupled 100Ω differential lines which should be terminated with 100Ω differential at the user SERDES. The AC coupling is done inside the module and thus not required on the host board.

**Note6.** VccR and VccT are the receiver and transmitter power supplies. They are defined as 3.3V±5% at the SFP connector pin. The in-rush current will typically be no more than 30mA above steady state supply current after 500ns.

**Note7.** TD-/+ : These are the differential transmitter inputs. They are AC coupled differential lines with 100Ω differential termination inside the module. The AC coupling is done inside the module and is thus not required on host board.

**Block Diagram**

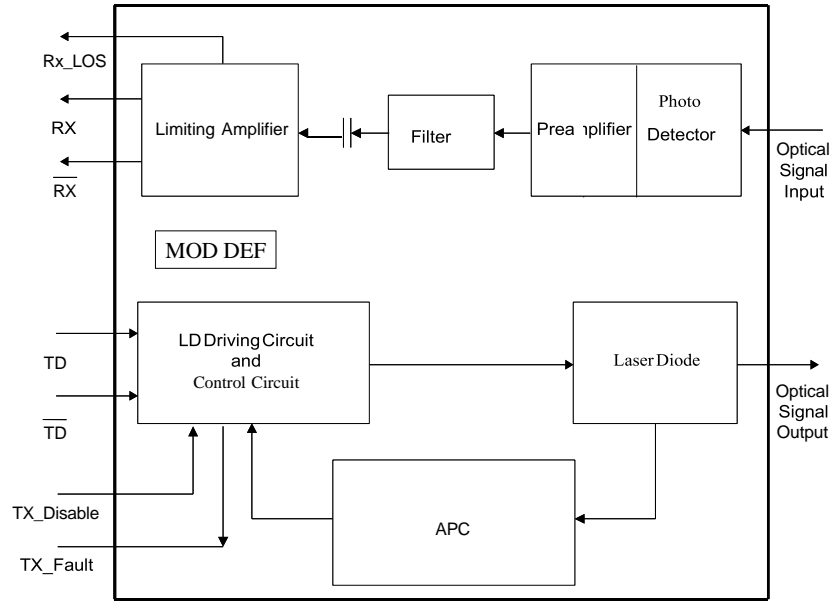

### Required Host Board Components

The MSA power supply noise rejection filter is required on the host PCB to meet data sheet performance. The MSA filter incorporates an inductor which should be rated 400mADC and 1Ω serial resistance or better. It should not be replaced with a ferrite. The required filter is illustrated in Figure 3. The MSA also specifies that 4.7K to 10KΩ pull-up resistors for TX\_FAULT, LOS, and MOD\_DEF0,1,2 are required on the host PCB. Figure is the suggested transceiver/host interface.

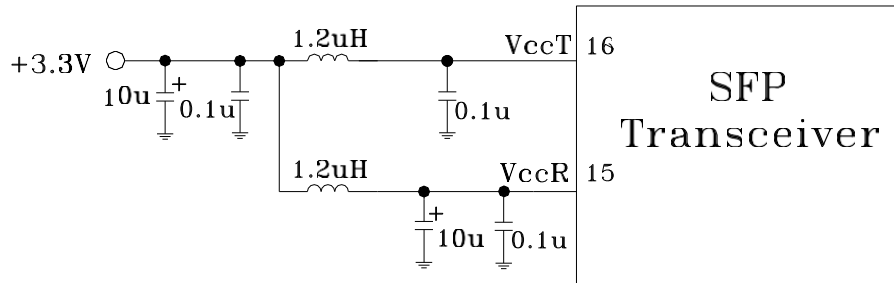

### Typical Application Circuit

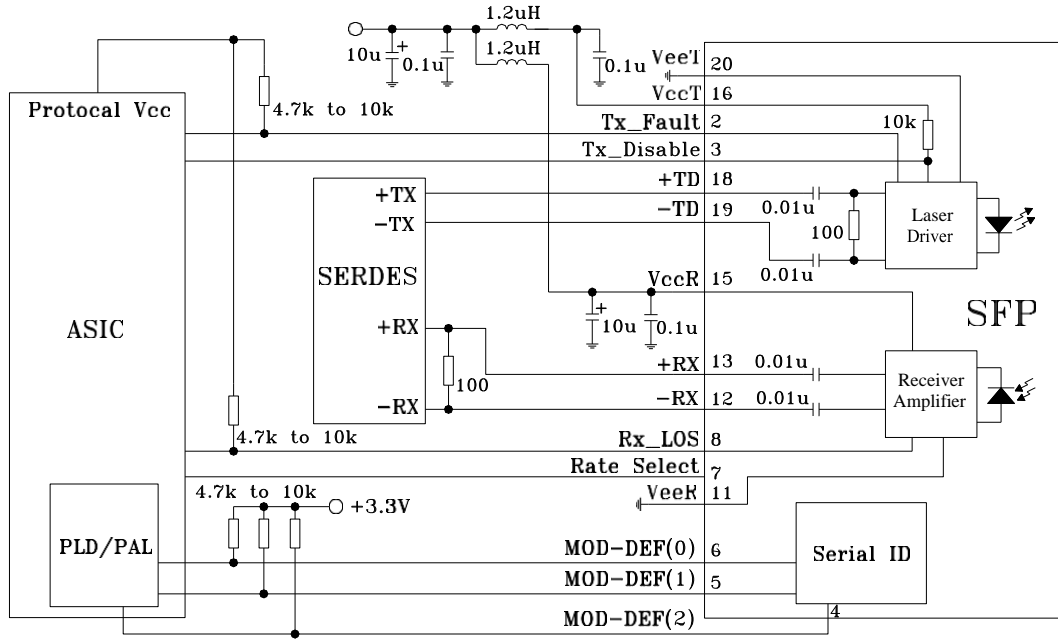

## PCB layout recommendation

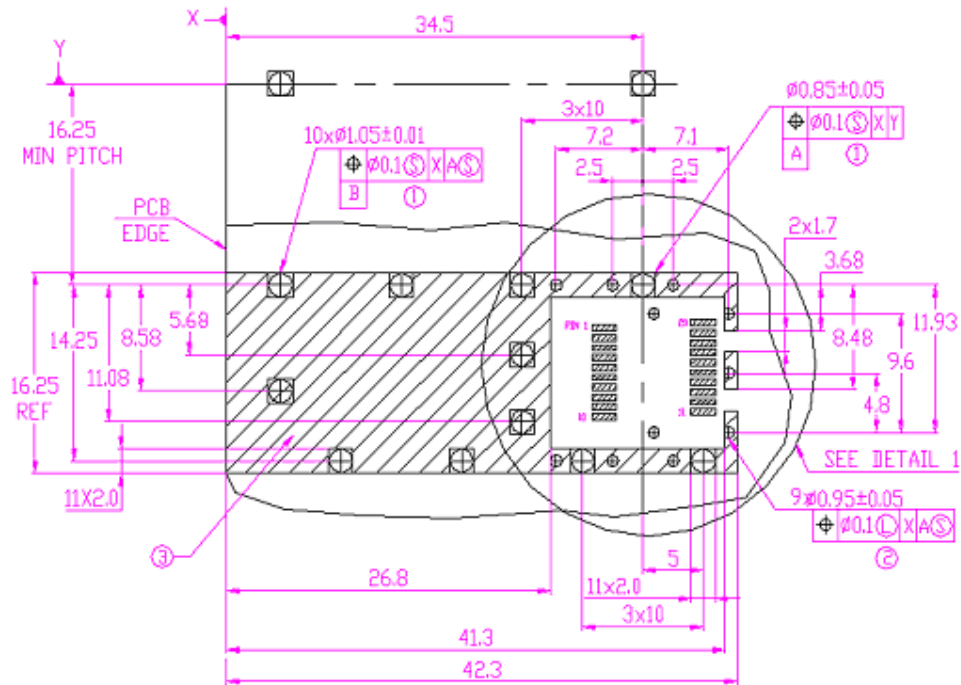

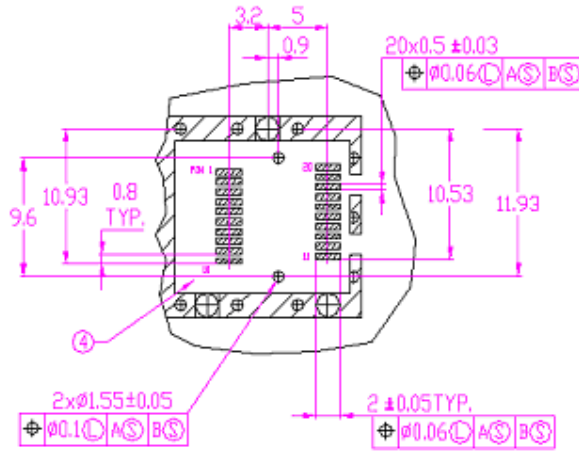

DETAIL 1

NOTES:

- 1.PADS AND VIAS ARE CHASSIS GROUND.
- 2.THROUGH HOLES,PLATING OPTIONAL.
- 3.HATCHED AREA DENOTES COMPONENT AND TRACE KEEPOUT (EXCEPT CHASSIS GROUND).
- 4.AREA DENOTES COMPONENT KEEPOUT (TRACES ALLOWED).

DIMENSIONS IN MILLIMETERS

**Regulatory Compliance**

Feature	Test Method	Performance
Electrostatic Discharge (ESD) to the Electrical Pins	MIL-STD-883E Method 3015.7	Class 1 (>1.5kV) – Human Body Model
Electrostatic Discharge (ESD) Immunity	IEC61000-4-2	Class 2(>4.0kV)
Electromagnetic Interference (EMI)	CISPR22 ITE Class B FCC Class B CENELEC EN55022 VCCI Class 1	Comply with standard
Immunity	IEC61000-4-3 Class 2	Typically show no measurable effect from a 3 V/m field swept from 80 to 1000MHz applied to the transceiver without a chassis enclosure.
Eye Safety	FDA CDRH 21-CFR 1040 Class 1 NO.:0322110-02	
	UL NO.: E239070	